

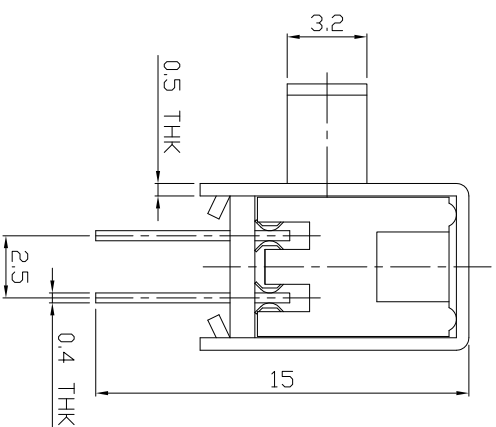

RoHS  
Compliant  
2002/95/EC

DIMENSIONS

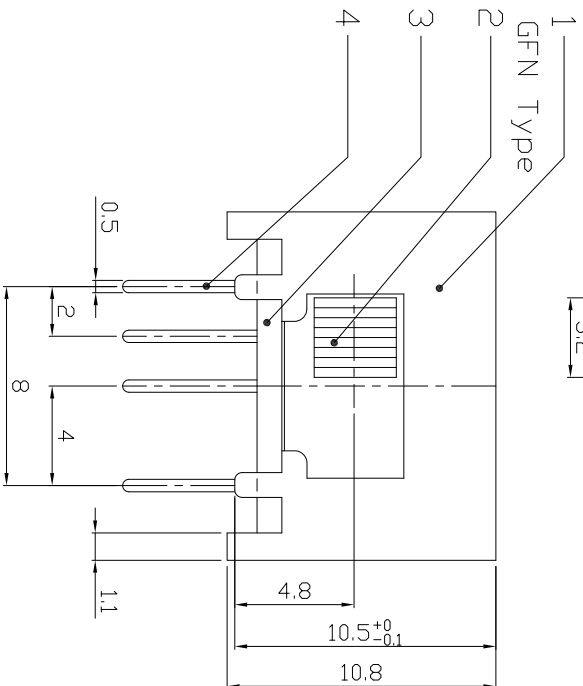
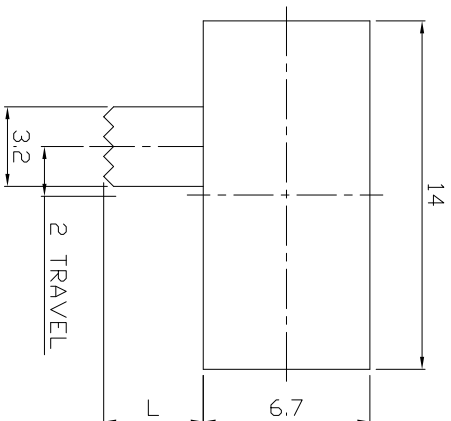

MODEL CODE

SK-22H01 - GFN

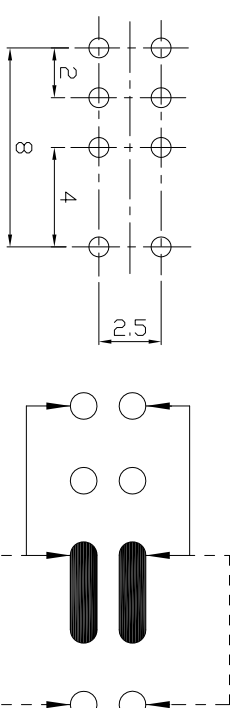
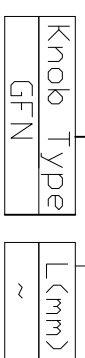

P.C.B LAYOUT  
BOTTOM VIEW

CIRCUIT DIAGRAM

ELECTRO-MECHANICAL CHARACTERISTICS

Refer to additional specifications

RATING	0.3A 50V DC
CIRCUIT	2P2T
CONTACT RESISTANCE	100mΩ MAX.
TIMING	NON-SHORTING
TRAVEL	2mm
OPERATING FORCE	250±100gf
OPERATING LIFE(cycles)	10,000

8	STEEL BALL	STEEL	1	NATURAL	WITHIN 1.5mm: ±0.1mm	UNITS	mm	<p><b>龙创中业电子（深圳）有限公司</b></p> <p>TITLE: SLIDE SWITCH / HORIZONTAL</p> <p>PART NO.: SK-22H01</p> <p>DWG NO.: ADL-22H01</p>
7	SPRING	STEEL WIRE	1	NATURAL	OVER 1.5mm: ±0.2mm	MAT'L	SEE NOTE	
6	CONTACT CLIP	PBS STRIP	2	AG PLATED		FINISH	SEE NOTE	
5	TERMINAL	BRASS STRIP	8	AG PLATED		Q'TY	APP'D:	
4	BASE	PHENOLIC RESIN	1	NATURAL		DR:	2016/06/27	
3	KNOB	POM	1	BLACK		CHK'D:	2016/06/27	
2	FRAME	STEEL STRIP	1	Ni PLATED		SCALE	1/1	
1	PARTS	MATERIAL	Q'TY	FINISHING		SHEET	A	

THESE DRAWINGS AND SPECIFICATIONS ARE THE PROPERTY OF ACCURATE INNOTECH INC. AND SHALL NOT BE REPRODUCED, COPIED OR TRANSMITTED IN ANY FORM OR BY ANY MEANS WITHOUT THE WRITTEN CONSENT OF ACCURATE INNOTECH INC.

REV.	ECN.	NO.	APPL.